

PART - 'X'

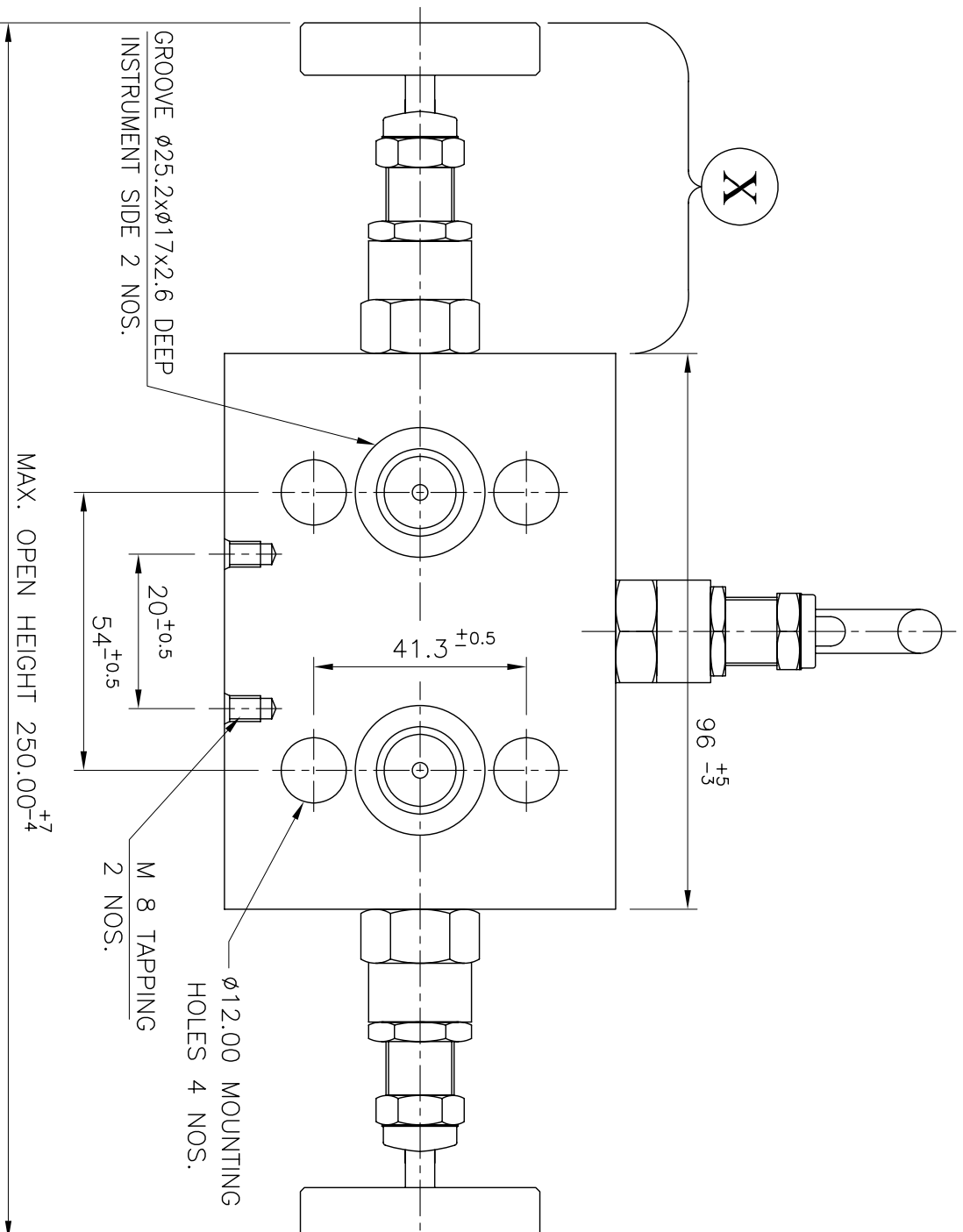
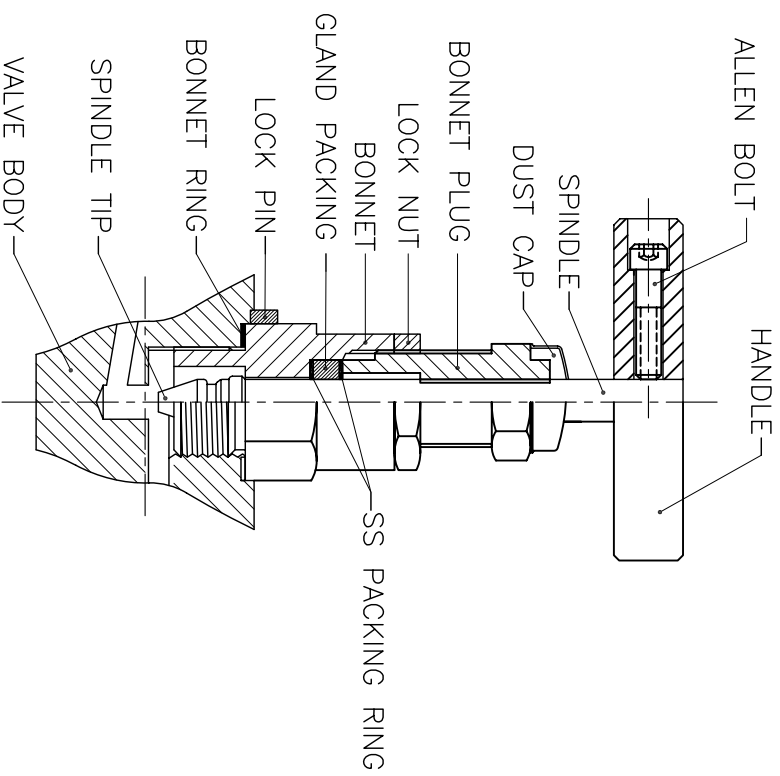

TECHNICAL SPECIFICATION

TITLE	DESCRIPTION
M.O.C.	BODY-ASTM A 182 F 316/316L & ALL OTHER SPARES ASTM A 479 GR.316/316L.
DESIGN	SCREWED BONNET
SPINDLE	NON-ROTATING 'V' TIP/'BALL' TIP
PACKING	d) PTFE AS STD UP TO MAX. 250 DEG & GRAFOIL AS OPTIONAL FOR HIGHER TEMPERATURE UP TO MAX. 648°C.
LOCK PIN	BONNET LOCK PIN TO PREVENT ACCIDENTAL LOOSENING.
IDENTIFICATION	COLOUR CODED ALUMINIUM STICKERS ON EACH BONNET AS APPLICABLE FOR ISOLATION, EQUALIZER & VENT ALONGWITH STEM DUST VINYL CAPS OF CORRESPONDING COLOUR.
HANDLE	SS 304 BAR TYPE WITH ALLEN BOLT.
VISUAL FINISH	MATT FINISH / ELECTRO POLISH FINISH.
MARKING	LOGO/BRAND NAME MODEL NO., M.O.C, PRESSURE RATING & FLOW DIAGRAM
LUBRICANT	d)ANTI SEIZE - NEVER-SEEZ b)THREAD SOLVENT - LOCTITE 542
THREADS	d)NPT THREAD AS PER ANSI B 2.1 b) BSPP THREAD AS PER BS 2779 c) BSPT THREAD AS PER BS21
HYDRO TEST	1.5 TIMES THE WORKING PRESSURE RATING (UPTO 1/2" - 6000 PSI & 3/4" / 1" - 3000PSI)
PNEUMATIC TEST	150 PSI
NITROGEN TEST	2000 PSI
TEST AVAILABLE UPON REQUESTS :	VIBRATION, TEMPERATURE CYCLING, HELIUM etc.
VALVES CAN BE SUPPLIED TO MEET CURRENT REVISION NACE MR-01-75	

*NOTE : ALL DIMENSIONS ARE IN MM FOR REFERENCE ONLY AND ARE SUBJECT TO CHANGE WITHOUT PRIOR INTIMATION.

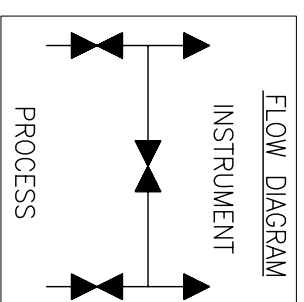

BAXCELL Instrument Valves & Fittings Pvt. Ltd.
(An ISO 9001:2008 COMPANY)

Title : **3 VALVE MANIFOLD DIRECT MOUNTING PIPE TO FLANGE**

DRAWING/MODEL NO.: **BAX-3VMCP-05**

SCALE : NTS	DATE :	REV. NO.
DRAWN BY	CHECKED BY :	00
APPROVED BY :		

DESIGN : BONNET ASSEMBLY